

Build Your Dream Power Your Life

BYD ENERGY STORAGE SOLUTIONS

**EFFICIENT
PROVEN
STABLE**

Headquarters

China
Bin GUO
Add.: Electric Power Research Institute
No.3009, BYD Road, Pingshan, Shenzhen
Postcode: 518118
Tel.: +86-755-89888888 ext. 57386
Email: eprisupport@byd.com

Sales Team

<p>North America Michael LIU Add.: 1800 S. Figueroa Street, Los Angeles, CA 90015, USA Tel.: +1 (213) 309-1887 Email: michael.liu@byd.com</p>	<p>Japan Tommy CHO Add.: Electric Power Research Institute No.3009, BYD Road, Pingshan, Shenzhen Tel.: +81 080-4955-6688 Email: tommy.cho@byd.com</p>	<p>Germany Wen JIANG Add.: Electric Power Research Institute No.3009, BYD Road, Pingshan, Shenzhen Tel.:+86 18998125030 Email: jiang.wen6@byd.com</p>	<p>United Kingdom Henry XU Add.: 3 Shortlands, London W6 8DA, United Kingdom Tel.: +44 7427 711069 Email: henry.xu@byd.com</p>	<p>West Europe Add.: 's-Gravelandseweg 256 3125BK Schiedam, The Netherlands Donglei FU Tel.: +31 634613392 Email: fu.donglei@byd.com Bono GE Tel.:+31 628241535 Email: bono.ge@byd.com</p>	<p>South America, Middle East & Africa Helen YU Add.: Electric Power Research Institute No.3009, BYD Road, Pingshan, Shenzhen Tel.:+86 13556263099 Email: helen.yu1@byd.com</p>
---	---	---	--	--	---

[Http://www.byd.com](http://www.byd.com) | [Http://www.bydenergy.com](http://www.bydenergy.com)

The company reserves the final right for explanation on any of the information presented hereby



ABOUT BYD

BYD Company Limited (“BYD”), as one of the Top 500 Chinese Enterprises, specializes in four industries including IT, automobile, new energy and rail transit. Its shares are listed on both Hong Kong Stock Exchange and Shenzhen Stock Exchange. ■

Founded in February 1995, BYD started out in the rechargeable battery business, and entered the automobile industry in 2003. In the meantime, it started operating in the renewable energy industry. In March 2016, BYD ventured into the light rail industry. By November 2016, BYD had a staff of **220,000** employees in **30** industrial parks around the world, covering an area of approximately **18** million sq. m. ■

BYD New Energy Global Impact

BYD provides a full set of new energy solutions to the generation, storage and utilization of electricity with its extensive new energy product lineup, including solar power stations, energy storage stations, electric forklifts, LED. ■

Its creation of a Zero Emissions Energy Ecosystem – comprising affordable solar power generation, reliable energy storage and cutting-edge electrified transportation – has made it an industry leader in the energy and transportation sectors. ■



Operating Records:

EV - 60 countries/ 150 cities

Solar - 4 GW

Energy Storage - 450 MWh

* As the end of 2017.11.31



<p>New Energy Vehicles</p> <p>11%</p> <p>Global Market Share</p>	<p>Globalization</p> <p>30</p> <p>Manufacturing Sites</p>	<p>Battery Capacity</p> <p>16 GWh</p> <p>Another 18GWh Battery Factory is under construction</p>
<p>Experiences</p> <p>24 years</p> <p>Battery manufacturing experience</p>	<p>Patents</p> <p>14,000</p> <p>Patents Authorized</p>	<p>Scope</p> <p>1</p> <p>World's Biggest Iron-Phosphate Battery Factory</p>



BYD Energy Storage Solutions

BYD Energy Storage System(ESS) technology offers a modular, flexible design and can be easily customized to meet diverse customer needs. Up to now, BYD has a lot of successful cases of battery storage solutions from KW sized to MW sized system at home and abroad. ■

Product Portfolio

As a market leader in the LiFePO4 technology, BYD is specialized in providing large-scale energy storage, distributed energy storage as well as micro-grid systems, which forms a complete set of energy storage system solutions. ■

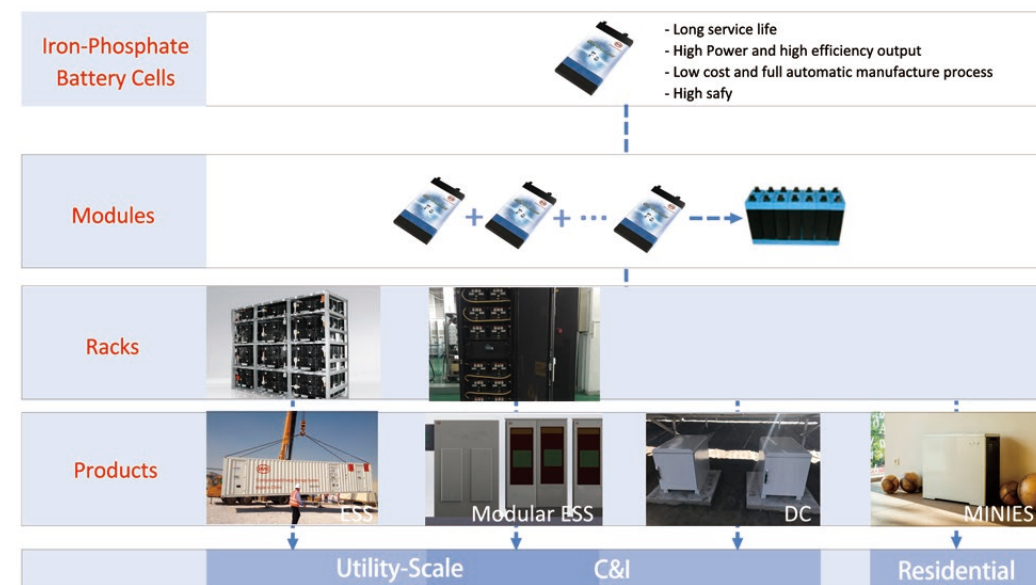

Illinois 31.5MW/12.06MWh ESS

System Parameter
System Capacity:31.5MW/12.06MWh
Project Location: Illinois,USA
Completion time: April.2015

Application
Frequency regulation



BYD Containerized Energy Storage System

ESS Application Field

- New-energy generation
- Stabilize new energy
- Frequency Regulation
- Emergency Back up
- Micro-grid
- Peak Load Shifting
- Capacity Reservation

*Special type needs

Military base, smelter chemical plant, paper mill, airport, wharf and others

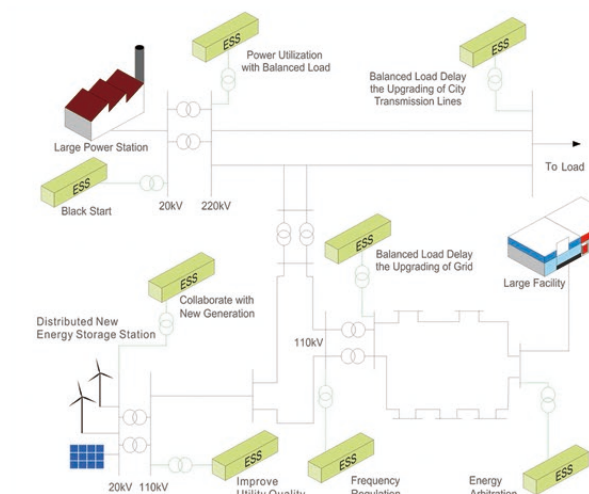

Specification

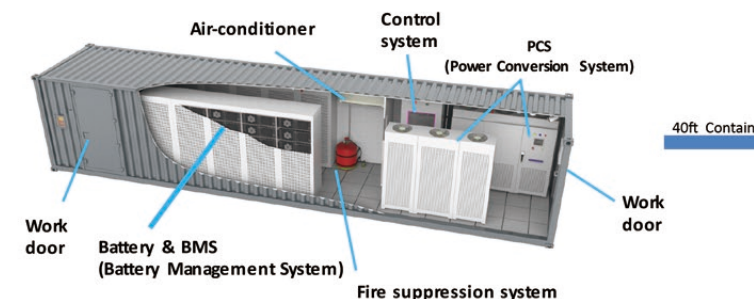

Operation Mode	Power	Nameplate Energy 290Ah Cell	Nameplate Energy 310Ah Cell	Nameplate Energy 330Ah Cell (2019*)
European Standard	1260kW	1655kWh	1777kWh	1883kWh
	630kW	1655kWh	1777kWh	1883kWh
	533kW	2068kWh	2222kWh	2354kWh
	400kW	2068kWh	2222kWh	2354kWh
American Standard	1000kW	1552kWh	1666kWh	1766kWh
	500kW	1552kWh	1666kWh	1766kWh
	480kW	1810kWh	1944kWh	2060kWh
Off-Grid	500kW	1552kWh	1666kWh	1766kWh

Cetification & Test Ability



UL WTDP



UL Certification



CQC Certification



QC/T Certification

Highlights of BYD Containerized ESS Projects

Accumuated Capacity: **462MW/463MWh**

*As the end of 2017



Capable ESS Project Capacity Scope: ~50+kWh ←-----●100kWh-----●1MWh-----●10MWh-----●100MWh-----●...~GWh

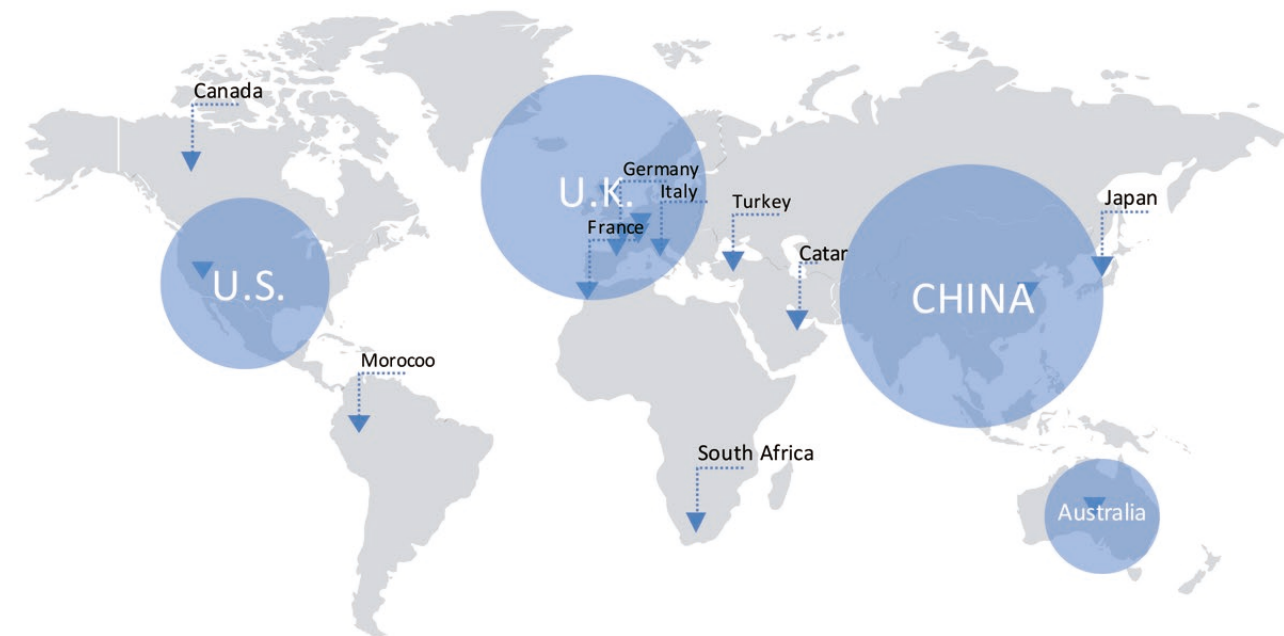

2MW/4.4MWh ESS Glacier, USA
Completion time: Mar. 2016
Owner: PSE
Application: Micro-grid



Chicago 19.8MW/7.865MWh ESS
System Parameter
Project Location: Chicago, USA
Completion time: Jan. 2016
Owner: EDF
Application: Frequency regulation



WV 31.5MW/12.06MWh ESS
System Parameter
Project Location: West Virginia, USA
Completion time: Nov. 2015
Owner: Invenergy
Application: Frequency regulation



1MW/2.6 MWh Los Angeles, USA
Completion time: Aug. 2017



1MWh Sicily Italy
Completion time: Mar. 2015



200kW/1.2MWh South Africa
Completion time: Mar. 2015



4MW/2MWh Ohio, USA
Completion time: February. 2014
Owner: RES
Application: Frequency regulation



WC 19.8MW/7.865MWh ESS
System Parameter
Project Location: WC, USA
Completion time: Dec. 2015
Owner: RES
Application: Frequency regulation



200kW/500kWh Charlotte, USA
Completion time: August, 2012



1MWh Sardinia Italy
Completion time: Dec. 2015



310 kW/668 kWh United Kingdom
Completion time: Jun. 2016



4MW/2MWh Ontario, Canada
Completion time: April. 2014
Owner: RES
Application: Frequency regulation

DC Energy Storage System eCHARGE

The DC Energy Storage System [eCHARGE] is co-developed by BYD and A-style Company Limited which is located in Japan. ■

Increasing the PV panel but making no change of the inverter, the use of [eCHARGE] to absorb excess electricity can increase the electricity sales. ■

System Topology

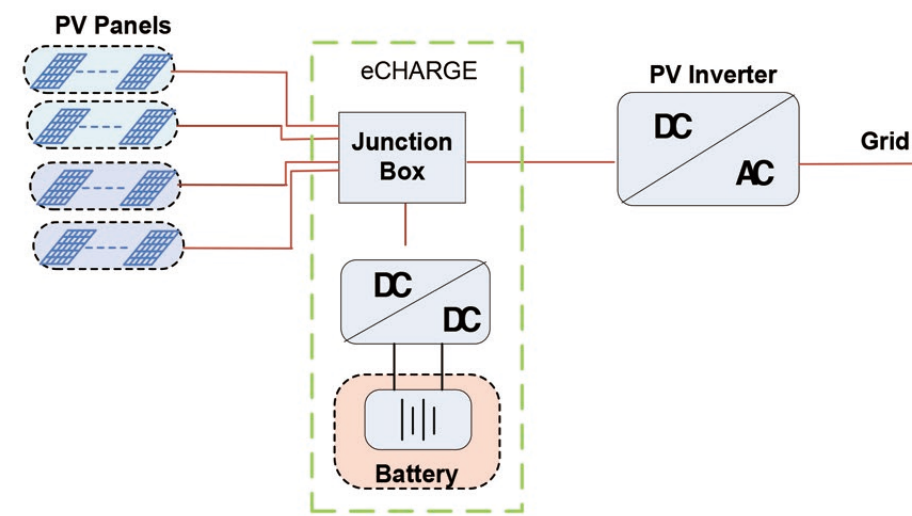

System working mode

- During the day, the electricity that PV panels generate will be sold, and the remaining electricity will be stored in eCHARGE.
- During the night, the electricity stored in eCHARGE will be sold.
- When the PV inverter is under maintenance, or failure to run, the electricity generated by PV can all be stored in eCHARGE.
- Capable of dealing with the power limitation by electric companies.

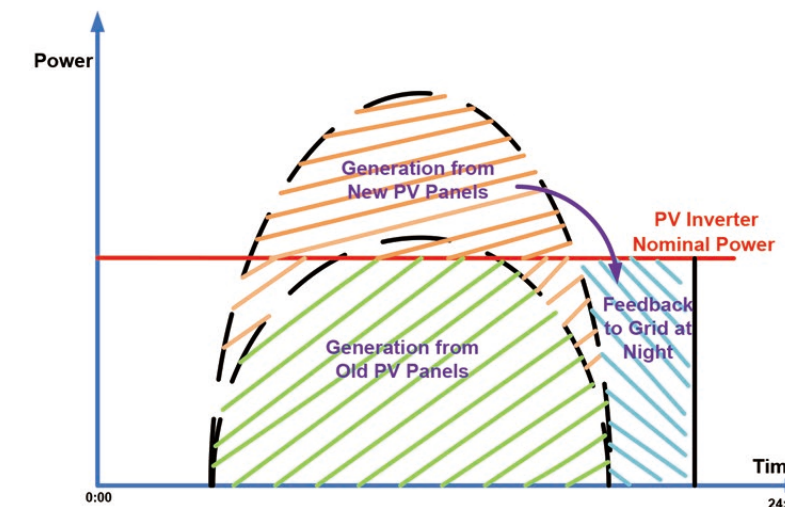

Specification

Name		Battery
NO.	Item	Parameter
1	Capacity	12 kWh
2	Nominal voltage	204.8V
3	Operation Voltage	179.2 ~ 230.4V
4	Battery type	Lithium iron phosphate (LiFePO ₄)
5	Working ambient temperature	-5°C ~ 40°C
6	Working ambient humidity	5% ~ 95%
7	Protection class	IP54
8	Altitude	≤2000m
Name		DCDC Converter
NO.	Item	Parameter
1	Nominal power	6kVA
2	Input	3
3	Maximum input current	9A×3
4	Working environment temperature	-20°C ~ 55°C
5	Working environment humidity	5% ~ 95%
6	Altitude	≤2000m
7	Protection grade	IP65
8	Size (W×D×H)	(W) 385mm × (D) 150mm (H) ×380mm
9	Weight	About 10 KG
Name		Junction box
NO.	Item	Parameter
1	Maximum open circuit voltage	600V
2	PV side operating voltage range	80V ~ 600V
3	Working environment temperature	-20°C ~ 55°C
4	Work environment humidity	5% ~ 95%
5	Altitude	≤2000m
6	Cooling Method	Natural cooling
7	Protection grade	IP54

Residential Energy Storage System MINI ES

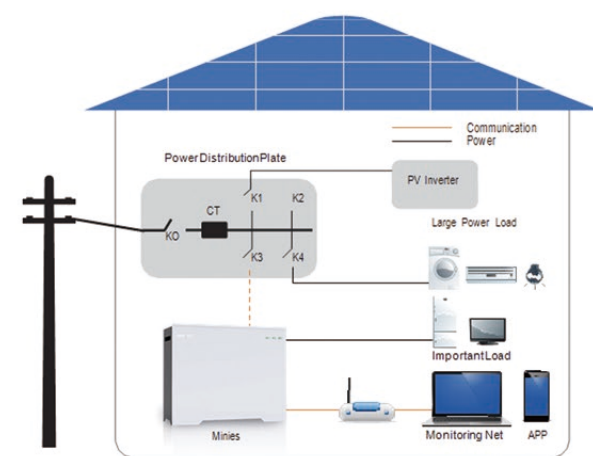

White box with elegant design, with various output and battery capacity. The system could be used together with solar system to achieve solar energy self-consumption application, also could be used in peak shaving, load shifting, off-grid power supply. ■

The system has the advantage of intelligence and integration, with advanced technology of LiFePO4, PCS, BMS, monitoring system, etc. And it can be remote monitored by the cell phone with APP (support iOS and Android). ■

The communication protocol is Modbus, system could be adapted with various remote controller to achieve different application. ■

- Easy installation
- Small size occupation
- Low noise level
- Intelligent monitoring
- Battery capacity extension ability



Specifications

Pic			
Maximum output	3kVA	3kVA	9kVA
System capacity	3kWh	6kWh	12kWh
Voltage/Frequency	230Vac/50Hz	230Vac/50Hz	400Vac/50Hz
Nominal voltage	52V	52V	52V
Type	LiFePO4	LiFePO4	LiFePO4
Altitude	<2000m	<2000m	<2000m
Operation temperature	0°C~40°C	0°C~40°C	0°C~40°C
Storage temperature	-10°C~40°C	-10°C~40°C	-10°C~40°C
Size	680mm(W) × 256mm(D) × 610mm(H)	680mm(W) × 256mm(D) × 610mm(H) + 466.5mm × 698mm × 199.5mm	600mm (W) × 800mm (D) × 1100mm (H)
Pure weight	About 96kg	96kg+57kg	280kg
Protection level	IP32	IP32	IP32
Standard	EN 62477-1, EN 62109-1/2, EN62040 CE-EMC VDE 4105, VDE 0126-1-1, G 83 IEC62619 UN38.3	EN 62477-1, EN 62109-1/2, EN62040 CE-EMC VDE 4105, VDE 0126-1-1, G 83 IEC62619 UN38.3	EN 62477-1, EN 62109-1/2, EN62040 EN 61000-6-2:2005 EN 61000-6-3:2007+A1:2011 VDE 4105, VDE 0126-1-1 IEC62619 UN38.3

BYD Modular Outdoor Energy Storage System

*CONCEPTUAL DESIGN

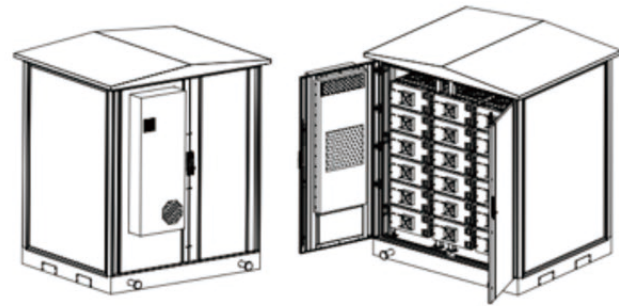

The Modular Outdoor ESS can be applied both to the Commercial and Utility scales. The main components of the Modular Outdoor ESS are the outdoor battery cabinet and the outdoor PCS cabinet. The battery cabinet integrates LiFePO4 batteries with distribution BMS system, having an advantage of higher safety, higher capacity, easy for maintenance and environmental friendly. ■

Schematic Diagram

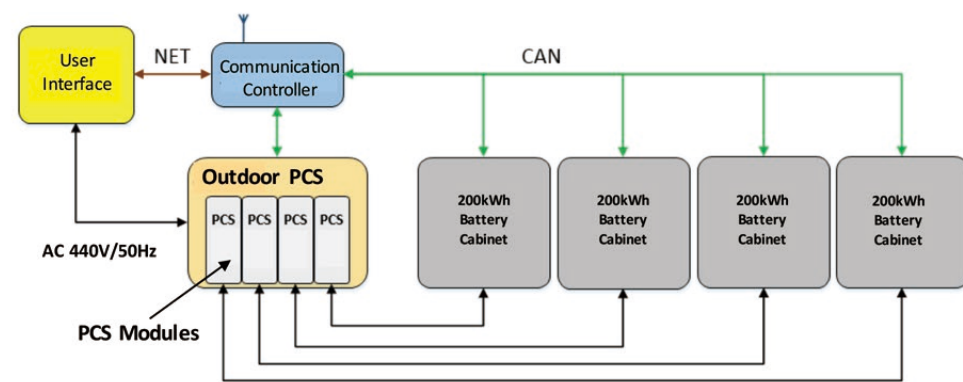

Specifications

Modular Outdoor Energy Storage System Unit	
System Function	Peak load pad, Match the PV, Frequency regulation
Working Mode	On-grid
Communication	Ethernet and RS485
Control Mode	Local/Remote
Application	Modular combination
Installation	Forklift / Crane
Delivery Cycle	65days
Reliability	MTBF>100,000H
Maintainability	MTTR<60Min
Availability	>98%
Altitude	<2000m
System Noise	<65db

Comparison

BYD	Container	Outdoor Unit
Delivery	120 d	65 d
Area Density	67.3 kWh/m ²	105.8 kWh/m ²
Bulk Density	23.6 kWh/m ³	55.7 kWh/m ³
Installation	Crane installation	<ul style="list-style-type: none"> Ordinary mobile forklift handling; Single cabinet installation time <60 Min

Outdoor Battery Cabinet

Image	Key Data	
		Rated Power
	Rated Capacity	245 kWh
	Protection Grade	IP55
	Dimensions (W*D*H) mm	1676*1381*1900
	Weight	About 2.9 t
	Temperature Range	-20°C~55°C
	Design Life	20 years
	Altitude	<2000m
	Noise	<65db

Outdoor PCS Cabinet

Image	Key Data	
		Topology
	Rated Power	800kW
	DC Voltage Range	678~850V
	Rated AC Voltage	440V
	Rated AC Current	1060A
	THD	≤ 5% full power
	Overload Capacity	1.1 times continuous operation
	Maximum Efficiency	98.2%
	Enclosure Protection Grade	IP54
	Permissible Environment Temperature	-25°C~+50°C
	Noise	<65dB
	Dimension (W/D/H) (mm)	1510/900/2300
	Weight (kg)	1700kg
	Design Life	25 years
	Power Density	256kW/m ³

Technological Advancement

- Advanced thermal control system**
 BYD cooperates with the air conditioning partner to co-design and co-develop the specialized industrial-grade air conditioners for BYD Modular Outdoor ESS. It is highly energy efficient and excellent cooling and heating performance, which contributes to the advanced thermal control system.
- Intelligent battery management system**
 BYD optimizes the current battery management system through advanced algorithm, updated control strategies, and smarter hardwares.
- Modularized integrated design.**
 And BYD firstly innovates the new modularized outdoor design by customizing the internal structure and developing the new outdoor enclosure for ESS.